

# CAS RL26



Conveyor  
Application  
Systems



## Reload Conveyor

### Simple

In a matter of minutes, the Reload Conveyor is quickly and safely set up and ready to feed. This versatile machine can load a variety of trucks.

### Mobile

Towed behind a standard pickup, the Reload Conveyor's lightweight design is extremely transportable.

### Functional

The Reload Conveyor is designed for quick loading of material while eliminating contamination of material from dumping on the ground.

### CAS Quality

At CAS we pride ourselves in the quality of all of our equipment. As an example, our fabricated components are individually powder coated prior to assembly so all surfaces are protected. And most important, we stand behind our product with ongoing support and manufacturer's warranty. CAS quality is the CAS difference.



# CASRL26

## Details and Specifications

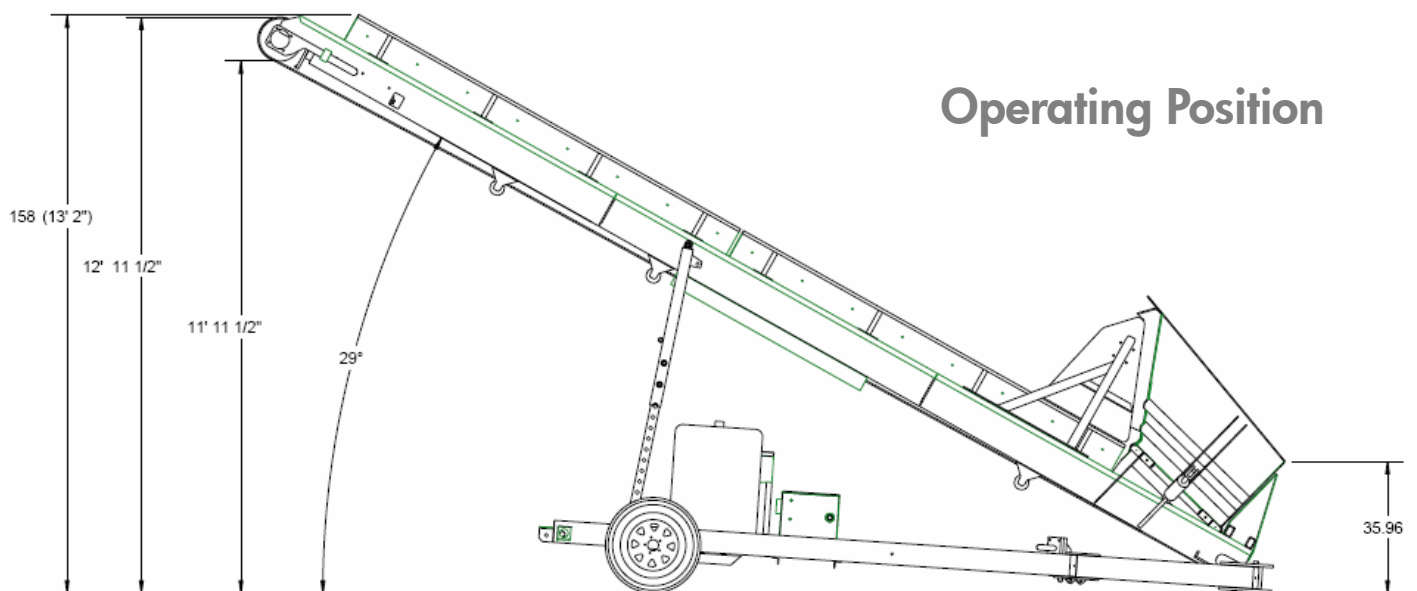
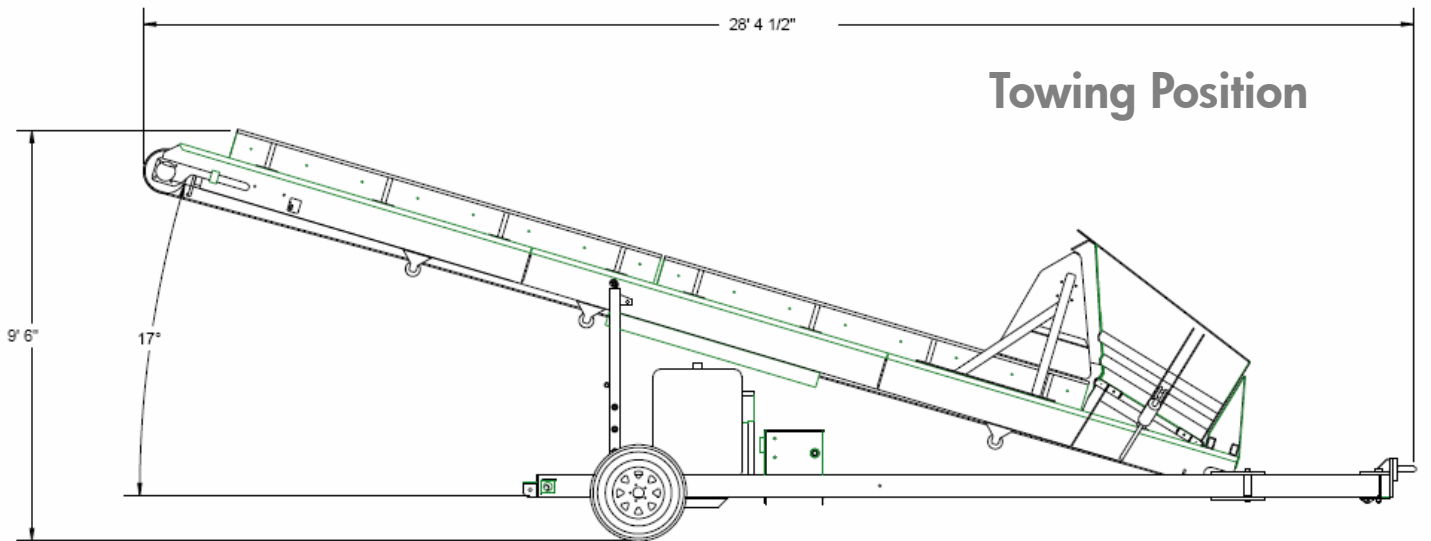

- 35 hp CAT Diesel Engine
- 48" Feed Belt
- Clearance Height: 12' (29° angle)
- Overall Length: 26'
- 10'9" Wide Winged Hopper
- Tow Weight: 6,800 lbs
- Tow Height: 9'6"
- Tow Length: 28'4"
- Production:
  - 4-6 tons of 1" rock per minute\*
  - 10-15 yards of organic material per minute\*

### Conveyor Application Systems, LLC

1275 Bailey Hill Road  
Eugene, OR 97402

1-888-279-4227

[www.slingers.com](http://www.slingers.com)

*\*Production volume varies widely depending upon material*



**Conveyor  
Application  
Systems**